



# Call for Quotes

## Wooden Library Boxes

### Issued by:

Municipality of the District of St. Mary's

Please send quotes by: **Feb. 10<sup>th</sup>, 2023**

Quotes can be sent by email to [kerri.jack@saint-mary.ca](mailto:kerri.jack@saint-mary.ca)  
or hard copy at the Municipal Office

Award Date: **March 2022**

**Description:** The Municipality of the District of St. Mary's is seeking a skilled wood worker to build six (6) wooden Library Boxes for communities throughout St. Mary's.

The specifications and instructions for building the library boxes are attached to this document. Instructions do not need to be followed exactly, but the completed library box should be made out of the recommended material and the final product should look the same as the instructions. If there is a recommendation for a change in design or material, please include details in the quote with an explanation. St. Mary's has a coastal climate, it is important for each box to be able to withstand that climate, please ensure boxes are water tight, but include proper ventilation to avoid mould. Each box must also include a stand to hold the library box. The specifications are not included in this document but should be included in quotes.

**Quote details:** Each quote must include cost for materials, labour and estimated time for completion of all six library boxes and stands. Installation is not a part of this project and does not need to be included in quotes. Each quote will be assessed on these three criteria: total cost, completion time and experience.

**Contact:** If you have any questions or require more information, please contact Kerri Jack at 902-522-2598 or by email at [kerri.jack@saint-marys.ca](mailto:kerri.jack@saint-marys.ca)



Learn how to register your Little Free Library on page 156.

## Modern Two-Story

The Modern Two-Story is a simple, stylish, and sizable structure with a sheet-metal roof. If you look closely, you'll notice that it looks a lot like the standard Two-Story Shed (page 75), but instead of the roof sloping from front to back, the Modern Two-Story's roof slopes from side to side. The door is on one of the sloping sides and follows the roof. This means that it's not a rectangle, but rather—as any geometry fan will tell you—a trapezoid. (You can crack up your math-nerd friends by calling it a “trapdoor.”)

The funky angles of the Modern Two-Story may make it seem harder to build than it really is. In reality, the design starts with a simple plywood box (as with most of the other projects in this book), and most of the trim pieces are square on one end and are miter-cut on the other end. To simplify several of the corner trims, you can glue together flat strips of wood to form L-shaped angles before cutting the pieces to length. Alternatively, if you have a tablesaw, you can cut these pieces from solid lumber and skip the gluing. In any case, it's best to have a power miter saw, or at least a miter box, for the many angled cuts.

The roofing is appropriately sleek and simple for this modern-style structure. It's made with a plywood rectangle topped with a single piece of sheet metal that is bent along one edge. Three L-shaped trim pieces finish it off, leaving the bottom edge open for water to run off to the side.

### INSTRUCTIONS

#### Cut the Plywood Parts

Cut the left side, right side, back, base, shelf supports, shelf, and roof deck to size using a circular saw or jigsaw. All the pieces are rectangular except for the back, which has an angled top edge. To lay out the back panel, mark it as a  $17\frac{15}{16} \times 22\frac{3}{16}$ -inch rectangle, then measure down  $2\frac{9}{16}$  inches from one top corner and make a mark. Draw a line from the mark to the opposing top corner. Cut along the angled line.

#### Assemble the Plywood Box

Cut the doorsill to length. Apply glue to one of its faces and position it against one long edge of the plywood base so it is  $1\frac{7}{8}$  inches from each corner and is flush with the top face of the base. Clamp the sill in place and let the glue dry. The edge with the sill is the front of the base.



1. The side panels fit over the edges of the base and back panel. 2. Notch the bottom end of each doorpost, cutting into the back face and bottom end of the post. 3. The post-header assembly fits between the side panels and serves as the front side of the structure.

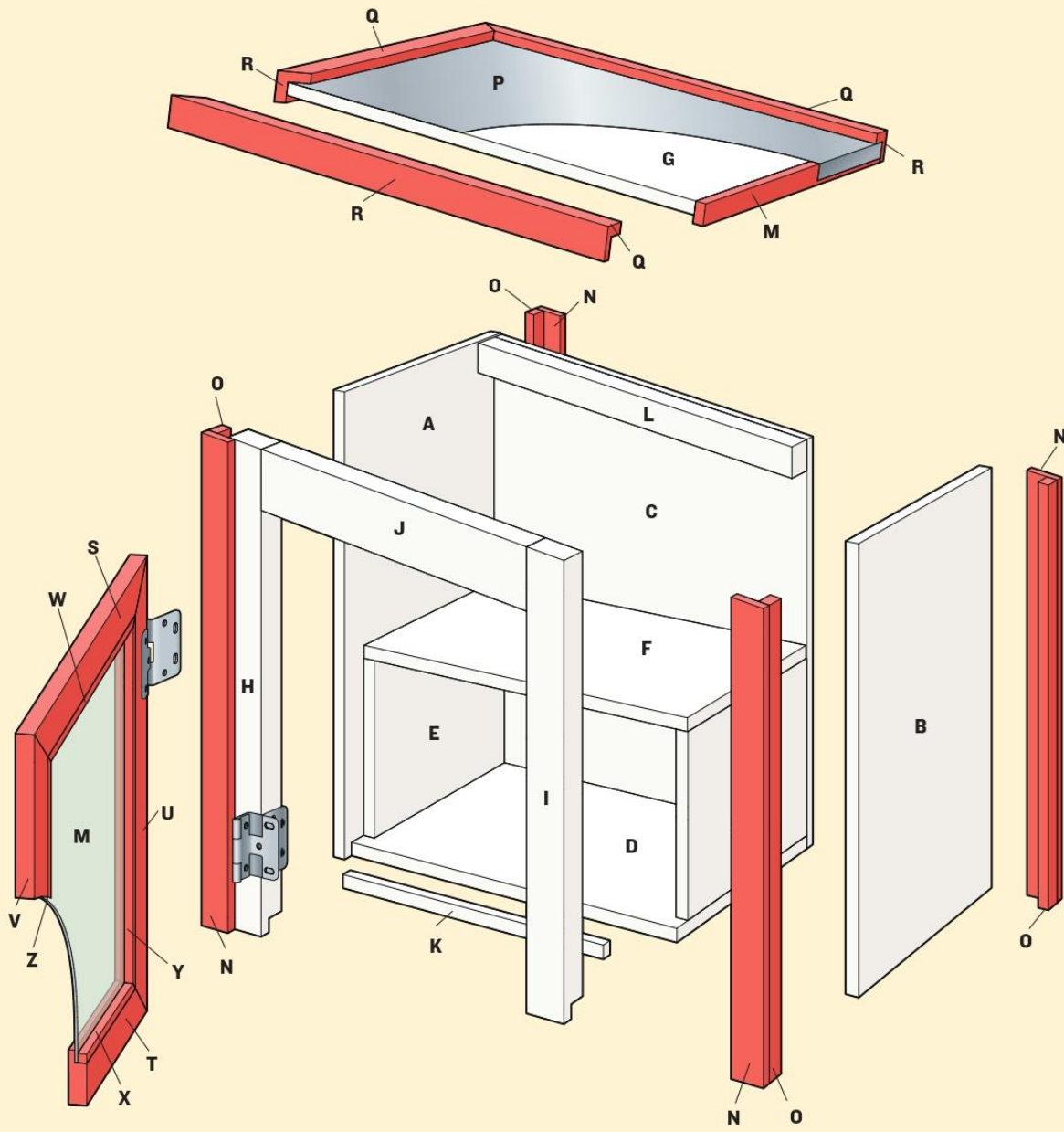



4



5



6



7

4. Glue the 1" stock to the face of the 1/2" stock to make 1/2" x 1/2" L-shaped corner trim. 5. Marking the direction of the miter cut on each corner trim helps you orient the piece on your saw when making the final cut to length. 6. Bend the bottom edge of the roofing, using the roof deck, a scrap board, or the edge of your work surface as a bending form. 7. Use the marked lines to fasten the roof deck to the roof cleat and door header.

Apply glue to the side and rear edges of the base and to both side edges of the back panel. Fit the back against the rear edge of the base, then fit the side panels over the edges of the back and base. Make sure all pieces are flush at the bottom and fasten along each edge with three 1 3/8-inch trim screws (photo 1).

### Add the Shelf Supports

Apply glue to one face of each shelf support, and fit it against a side panel, butted against the base and back panel. Secure each support with four 1-inch screws driven through the support and into the side panel.

The shelf merely rests on top of the shelf supports, so you can remove it as needed to make room for tall items. Put the shelf in a safe place for now and drop it in place later when it's time to fill your structure.

### Cut the Front Posts and Door Header

The two front posts and the door header are made from 2 x 4 lumber that is first rip-cut to width before it is cut to length. Each doorpost gets a notch at the bottom to fit over the front edge of the plywood base.

Cut an 8-foot 2 x 4 into two 48-inch pieces, then rip-cut one of the halves to 1 7/8 inches wide using a circular saw and a straightedge guide (see Making Straight Cuts on page 31). Using the ripped piece, cut the left and right doorposts to length with a miter saw or miter box, mitering the top ends at 8 degrees and leaving the bottom ends square.

Cut a 7/8-inch-wide x 3/16-inch-deep notch into the bottom end of each doorpost using a circular saw, jigsaw, or handsaw (photo 2).

Using the remaining half of the 2 x 4, rip-cut a 16-inch section to width at 2 3/4 inches. Cut the ripped section to

length at 14¾ inches, mitering both ends at 8 degrees, so the two miters are parallel. You will use the leftover 2 × 4 lumber later to create the roof cleat.

### Install the Front Posts and Header

Apply glue to the right end of the door header. Fit the right doorpost against the glued end so the pieces are perfectly flush at the sides and top. Drill two pilot holes through the outside edge of the post and into the end of the header, then fasten the pieces with two 3-inch screws. Repeat the same process to install the left doorpost at the other end of the header, creating an upside-down U-shaped assembly.

Glue the outside edges of the doorposts and the notches at the bottom ends of the posts. Fit the post-header assembly between the side panels of the box so the notches fit snugly onto the base; they will slide into the spaces created by the doorsill. The top ends and front faces of the posts should be flush with top and front edges of the side panels, respectively.

Fasten the side panels to each post with three 1¼-inch screws (photo 3). Lay the structure on its back. Drill two pilot holes through the base and into each post and fasten the base to the posts with 3-inch screws.

### Assemble the Corner and Roof Trim

The four corner trims and three roof trims are L-shaped pieces made by gluing 1-inch-wide stock to 1½-inch-wide stock. It's most efficient to make two long assemblies, then cut all the pieces to length. You will also cut the roof-eave trim from some of the extra 1-inch-wide stock to use later.

Cut one of the 1½-inch and one of the 1-inch pieces of pine stock to length at about 68 inches. Cut the leftover piece of 1-inch stock to length at 17¾ inches and set it aside to use as the roof-eave trim.

Apply glue to one of the side edges of the 68-inch piece of 1-inch stock and fit the piece against the face of the 68-inch piece of 1½-inch stock to form an L shape. Clamp the pieces together in several places. Let the glue dry for at least 1 hour before removing the clamps. Glue together the remaining 8-foot pieces of 1-inch and 1½-inch stock to create another L assembly (photo 4).

**Tip:** If you don't have enough clamps for the long assembly, you can cut the pieces in 24-inch or 48-inch lengths and glue them up in shorter sections.

### Install the Corner Trim

You will use the 8-foot-long trim assembly to cut the four corner trim pieces to length with a miter saw or miter box.



**8.** Glue the roof-trim angles to the roof deck and tack them in place with finish nails. **9.** Fasten each miter joint of the doorframe with a 3" screw driven at a 45° angle.

Plan each cut before making it. Each trim piece is square-cut at the bottom end and miter-cut at the top end at 8 degrees. When installed, the 1-inch-wide piece of each L assembly fits against a side panel so that the joint between the trim boards is visible at the sides of the structure. It's helpful to position each piece on the structure and make a rough reference mark indicating the direction of the miter cut (photo 5).



**10.** Add the door glazing and reinstall the door after finishing the structure.

Cut the two longer corner trims—for the left side of the structure—to length at  $22\frac{5}{16}$  inches. Cut the two shorter corner trims—for the right side of the structure—to length at  $19\frac{11}{16}$  inches. Glue the inside faces of each trim angle, position it on the box so it is flush with the top edges of the plywood panels, and fasten it through the side piece of the angle with three  $\frac{1}{4}$ -inch finish nails.

### Prepare the Roof

Glue one face of the roof eave trim and fit it against one of the  $17\frac{1}{4}$ -inch edges of the plywood roof deck so the trim is flush with the top face of the deck. Nail the trim in place with three  $\frac{1}{4}$ -inch finish nails.

Cut the sheet metal roofing to size using aviation snips. Bend one of the 17-inch edges at 90 degrees to create a  $\frac{1}{2}$ -inch wide lip along the bottom edge of the roof (see Working with Sheet Metal on page 37 for tips on working with sheet metal) (photo 6). The lip will fit over the eave trim at the bottom of the roof.

### Install the Roof Deck

Cut the roof cleat from a leftover piece of  $2 \times 4$  material: First, rip-cut a 20-inch-long section to  $1\frac{1}{2}$  inches wide. Then, cut the ripped piece to length at  $18\frac{3}{8}$  inches, mitering both ends—with the miters parallel to each other—at 8 degrees.

Glue one face of the roof cleat and position it against the inside face of the back panel, flush with the top edge. Fasten the cleat with three  $1\frac{3}{8}$ -inch trim screws driven through the outside of the back panel.

Draw two lines on the roof deck, parallel to the long edges, for locating the screws that will fasten the roof deck to the roof cleat and the door header. Draw the rear line  $3\frac{3}{16}$  inches from the rear edge of the roof deck; draw the front line  $2\frac{9}{16}$  inches from the front edge of the roof deck.

Apply glue to the top edges of the roof cleat and door header. Position the roof deck on the box so it overhangs equally side to side and front to back. Fasten the roof deck to the roof cleat and door header with three  $1\frac{3}{4}$ -inch screws each (photo 7).

### Complete the Roof

Apply a wavy bead of silicone caulk to the roof deck. Lay the sheet-metal roofing onto the deck so it is centered side to side and the lip at the bottom is snug against the eave trim at the bottom edge of the roof deck. Set a scrap of plywood or scrap boards onto the roofing and clamp the pieces in place. Let the caulk cure overnight, then remove the clamps and scrap wood.

Glue the top edge and side edges of the roof deck. Fit the three roof-trim angles over the top and side edges of the roof so the mitered ends meet snugly at the top corners. Secure each trim piece with three 1-inch finish nails driven through the side of the trim and into the roof deck (photo 8).

### Build the Doorframe

Rip-cut an 8-foot-long  $1 \times 3$  board to width at  $2\frac{3}{16}$  inches. Cut a  $\frac{1}{2} \times \frac{1}{2}$ -inch rabbet along at least 72 inches of the board using a circular saw and straightedge guide or a router and  $\frac{1}{2}$ -inch rabbeting bit (see Making Doors with (or without) Rabbets on page 34 for help with cutting rabbets). You will cut all the doorframe pieces from the rabbeted section of the board.

**Note:** All of the miter cuts on the doorframe pieces—and the glazing stops—are described as they are viewed from the front of the door. Cut each piece of doorframe to length with the following miters; also cut each corresponding glazing stop to length using the same angles:

Top piece, left end: 49 degrees; top piece, right end: 41 degrees

Left piece, top end: 49 degrees; left piece, bottom end: 45 degrees

Right piece, top end: 41 degrees; right piece, bottom end: 45 degrees

Bottom piece, both ends: 45 degrees

Dry-assemble the doorframe (no glue) and clamp it both directions. Drill a pilot hole at each corner of the frame, angling the hole at 45 degrees through the top/bottom piece and into the side piece. Make sure the hole does not interfere with the rabbet on either piece.

Unclamp the frame pieces, apply glue to the end of each piece, and assemble the frame with a 3-inch wood screw at each joint (photo 9).

Measure the width and height of the doorframe opening, measuring from rabbet to rabbet. Subtract  $\frac{1}{8}$  inch from each dimension, then cut the door glazing to this size (see Cutting and Drilling Plastic Glazing on page 35). You will install the glazing after painting or staining the project.

### Hang the Door

The door is hung with offset-style hinges (sometimes called institutional hinges) that mount to the left doorpost and to the back side of the doorframe. Mount the hinges to the

doorframe, about  $2\frac{1}{2}$  inches from the top and bottom edges of the frame, using the provided screws.

Position the doorframe so it is aligned with the bottom of the box base and fasten the hinges to the left doorpost with the provided screws. Remove the doorframe and hinges for the finishing process.

### Complete the Project

Finish the project as desired (see Painting & Staining on pages 39–42 for finishing tips). When the finish is completely dry, fit the glazing into the rabbets of the doorframe and secure it with the glazing stops, nailed at each end and in the center with 1-inch finish nails. Rehang the door as before (photo 10).

Apply a fine bead of caulk along the edges of the roof trim, to seal the joint where the trim meets the metal roofing. Let the caulk dry overnight.

Position the shelf on top of the shelf supports inside the structure, if desired.

